

MOBILE CONTAINERS FOR RECYCLABLES AND WASTE

# 2-WHEEL CONTAINERS

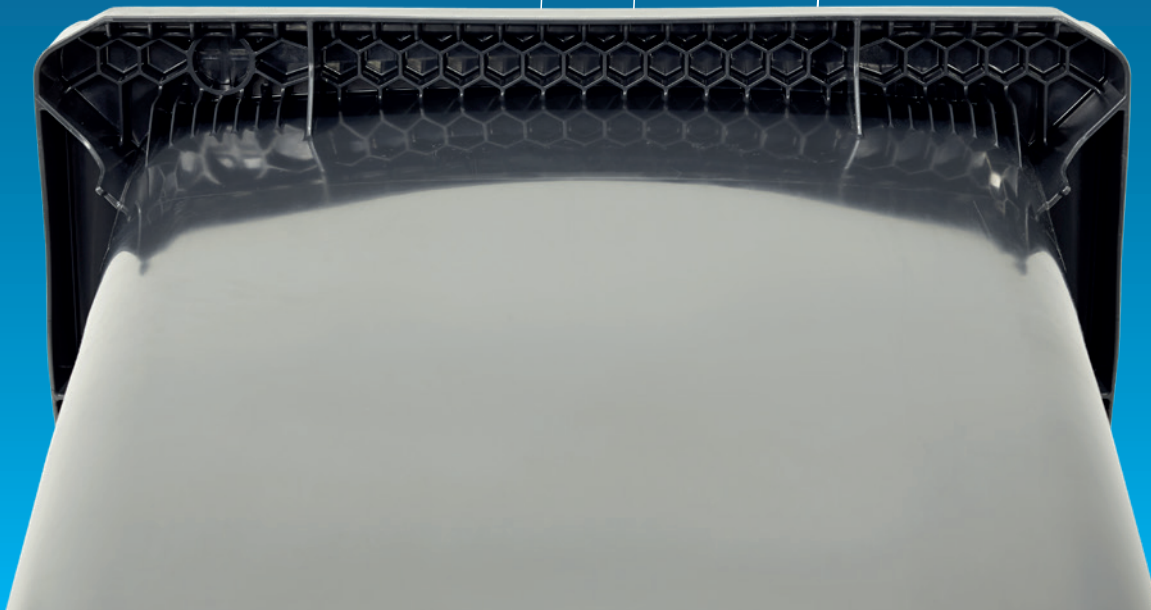
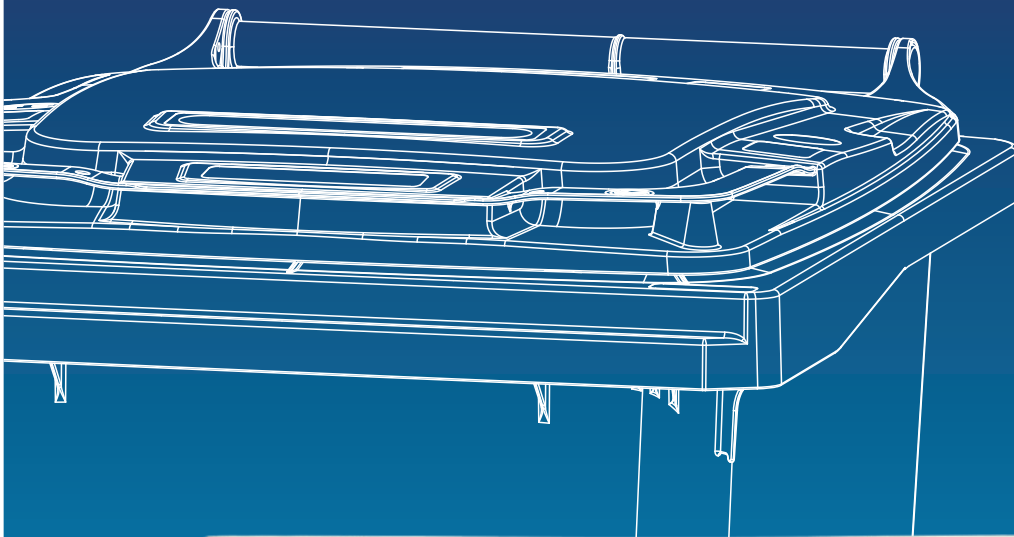

# DIVERSITY ON TWO WHEELS

## FUNCTIONAL AND CONFORMING TO STANDARDS

Containers for waste and recyclables have to fulfil requirements as diverse as the ESE product portfolio on two wheels. Volume size and colour, ergonomic details and features for easy emptying can be combined at will. Quality is as important as environmental aspects and conformance with norms. Sustainability aspects, recyclability and noise reduction as well as good handling of the containers determine the development of our products.

## COMPREHENSIVE STANDARD

- All ESE 2-wheel containers come with the following features:
- Greater depth of comb receiver to ensure optimal lifting security
  - Additional honeycomb structure for safety and a long product life
  - Eight ribs in the chip nest to secure the position of the chip
  - Solid rubber tyres
  - 19 standard colours, additional colours on request
  - Optimised handle design for better ergonomics and efficient handling
  - RAL-certified

## MISSION FOR QUALITY

Our efforts are characterised by a distinct responsibility for our products. Eco-friendly materials, usable volume sizes and long product life characterise our product philosophy.

The material HDPE possesses the following advantages:

- Environmentally friendly
- Recyclable
- Long life expectancy
- Frost-proof
- Chemical-resistant
- High UV resistance

## IDENTIFICATION OPTIONS

All ESE 2-wheel containers can be labelled individually as follows:

- Hot-foil stamping e.g. city arms
- Injection moulding e.g. council name
- In-mould labelling on request



Hot-foil stamping

## CONTAINER MODELS

### CL BODIES



### SL BODIES



### SMALL-SIZE BODIES



### CL BODIES

- Product design for low carbon emission
- Foot step for easy tilting
- Low noise wheels

### CL LID WITH CLIP

- Handle strip on three sides combined with bow handles
- Condensation edge inside
- Ready for noise reduction features
- Available and upgradable with coloured clips for identification

### SL BODIES

- Optimised design for side loaders
- Foot step for easy tilting
- Low noise wheels (360 SL on request)
- Wheel size 200 mm, 250 mm resp. 300 mm on request

### SL HANDLE STRIP LID

- Handle strip on three sides optimised for SL body design
- Condensation edge inside
- Ready for noise reduction features

### SMALL-SIZE BODIES

- Designed for small volume sizes 40-80 l
- Stable construction

### GL HANDLE STRIP LID

- Handle strip on three sides
- Condensation edge inside
- Ready for noise reduction features

## LID DESIGNS

### CL MULTI-PURPOSE LID WITH CLIP



### SL HANDLE STRIP LID



### GL HANDLE STRIP LID



# SMALL CLIP LARGE IMPACT

## SUSTAINABLE DESIGN

The new CL product line from ESE is a study in sustainable design. Quality is one of the main criteria for an eco-friendly product because it rarely needs exchanging.

Weight impacts handling and transport. The unique stable design and an innovative production technique allow us to build a lightweight product with a very long product life.



Due to their extraordinary stackability and low weight CL containers are optimised for transport and thus reduce the carbon footprint considerably.

Lower use of materials saves resources and high quality guarantees a long product life. Coloured identification clips allow flexible use of the containers and the use of up to 100% of recycled material for production.



The CL series can be provided with exchangeable clips in different colours on request.



Low noise wheels and lid silencers reduce the sound emission. The construction allows easier tilting of the bin.

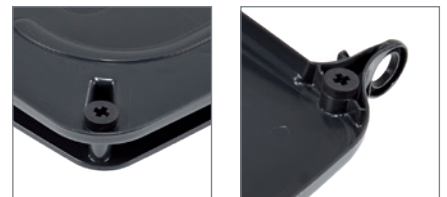

Rubber silencers for low sound emission on request



Noise reduction for lid



120 L



140 L



180 L



240 L



ESE CL containers are available with various insertion options for different waste fractions. Various lock options from pad lock to gravity lock and other special features are also available on request.



Triangular lock



Gravity lock



Padlock



CL container with highway post

## TECHNICAL DATA

MGB	120 CL	140 CL	180 CL	240 CL
Nominal Volume (l)	120	140	180	240
Weight of container (kg)	8	9	10	11
Max. permissible weight (kg)	60	70	90	110
A Overall height (mm)	932	1030	1004	1003
B Overall width (mm)	480	480	480	580
C Overall depth (mm)	553	553	737	738
D Height to upper edge comb (mm)	872	969	940	938
E Wheel diameter	200	200	200	200

## MEASUREMENTS

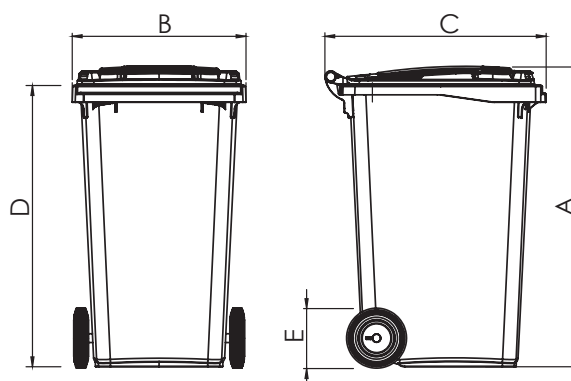

These details are subject to technical changes. The products contain no substances from the SVHC list of the European Chemicals Agency (ECHA).



# WHICH SIDE ARE YOU ON?

## ON THE SAFE SIDE

As a product optimised for side loaders, SL stands for efficiency and flexibility and is clearly recognisable by the vertical reinforcing beading on the front and rear sides. The latest structural and ergonomic know-how has been incorporated into all ESE SL containers. The integrated foot step protects the users' back whilst the noise reduction in the wheel mounting area ensures quiet operation.



Ergonomic foot step

## COMPREHENSIVE STANDARD

- Reinforcing beading for stabilisation on front and rear of the container
- Easy tilting on the rear wheels to get over kerbs
- The entire SL range comes with a wheel diameter of 200 mm or larger on request
- Low noise wheels (360 SL only on request)
- Axles can be kept in the rim of stacked containers (except 240 SL)

Further options are available for the SL series e.g. holder for refuse bags, highway post and foot-operated lid opening.



## TECHNICAL DATA

MGB	120 SL	180 SL	240 SL	360 SL
Nominal Volume (l)	120	180	240	360
Weight of container (kg)	9	12	13	15
Max. permissible weight (kg)	60	90	110	160
A Overall height (mm)	974	1065	1079	1112
B Overall width (mm)	479	479	583	585
C Overall depth (mm)	555	744	737	880
D Height to upper edge comb (mm)	905	990	1005	1020
E Wheel diameter	200/250	200/250	200/250	200/300

## MEASUREMENTS

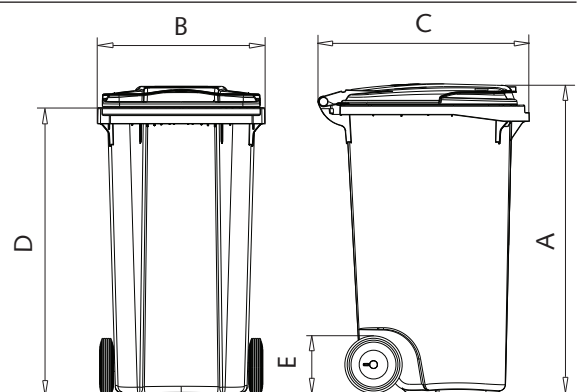



120 L



180 L



240 L



360 L

The ergonomically designed handle bar with large diameter ensures safe handling.

The 120 SL container is available with a third handle on request. The position of this handle at the front bottom makes it easy to handle in basements for example.

For more comfortable use the entire SL series is equipped with 200 mm wheels or larger on request.

The ergonomic foot step allows easy tilting for easier navigation of kerbs.

The DIN comb receiver has a honeycomb structure for safety and a long product life.

The ESE SL series can be equipped with a gravity lock or other lock options on request.

The SL lids are available with different insertion options.



Asymmetrical handle bar construction for a safe handling



120 SL with third handle on request



Wheel diameter 200 mm or larger on request



Robust comb receiver



Gravity lock option



Lid silencers reduce the sound emission

# SMALL SIZE GREAT PRODUCTS

## GREAT IN EVERY DETAIL

The ESE product range offers the perfect 2-wheel container for each request. Our small size bins replace the former round bins and are available in high quality and with comprehensive standard configuration.



40 L

60 L

80 L

## SELECTION OF OPTIONS

Locking devices

Various insertion options

Individual labeling

Noise reduction

Identification options

Highway posts



Handle bar Ø 27 mm

## TECHNICAL DATA

MGB	40	60	80
Nominal Volume (l)	40	60	80
Weight of container (kg)	9	9	9
Max. permissible weight (kg)	40	50	50
A Overall height (mm)	930	940	940
B Overall width (mm)	480	445	445
C Overall depth (mm)	554	520	520
D Height to upper edge comb (mm)	866	872	870
E Wheel diameter	200	200	200

## MEASUREMENTS

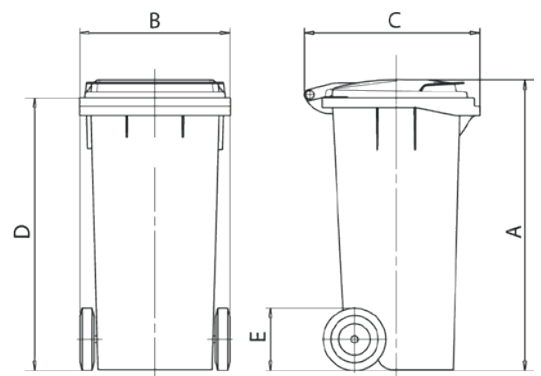

These details are subject to technical changes. The products contain no substances from the SVHC list of the European Chemicals Agency (ECHA).



# GREY - MORE COLOUR FOR THE ENVIRONMENT!

## COLOUR CONCEPT - FORMULA FOR THE ENVIRONMENT

The ESE colour concept is based upon a simple equation: less colour = more recycling. Dark-grey basic containers, produced from up to 100% recycled plastics, are combined with coloured lids for waste fraction identification. Our new recycling colours are also part of the concept. Three different shades allow the colouring of virtually every recycling material - no matter which original colours the material had.

## COLOURFUL FLEXIBILITY

Colour concept means there's no need to compromise. 19 lid colours are available. If 2 or 4 wheels - our colour concept is available for all ESE containers. This makes your container management becomes easier and stock and logistics costs are reduced.

## THE BLUE ANGEL: A SIGN FOR THE ENVIRONMENT

The Blue Angel is the world's first eco-label. The German Federal Environment Agency develops the strict award criteria.



[www.blauer-engel.de/uz30a](http://www.blauer-engel.de/uz30a)

## CERTIFIED SUSTAINABILITY

Sustainable containers from ESE can from now on\* be awarded with the eco-label "Blue Angel - Because made from recycled plastics". Origin and composition of the recycled plastics used have to be proven and certified according to euCertPlast.



## 16 STANDARD COLOURS

Use of recyclate without restriction 

FC020	RAL9011
FC030	RAL7021

Limited use of recyclate 

FC040	RAL6011	FC081	RAL5015
FC144	RAL6012	FC032	RAL7038
FC049	RAL6017	FC200	RAL7045
FC110	RAL1011	FC037	RAL7013
FC090	RAL8025	FC034	RAL7011

Not suitable for the use of recyclate 

FC060	RAL2010
FC070	RAL3020
FC010	RAL9016
FC050	RAL1018

\* available upon request

# PASSED WITH DISTINCTION

## NORMS FOR SAFETY

Certified quality provides safety in logistics and handling. All elements harmonise. Independent institutions verify the compliance with requirements for filling, emptying, handling, health and safety. ESE containers fulfil all European and national norms and standards and are certified in accordance with the highest standard worldwide, the RAL-GZ 951/1.



## CERTIFIED QUALITY

National and European norms define the basic requirements for safety and compatibility of mobile containers. Only the RAL quality certification set much higher standards and require a continuous monitoring of production. They thus guarantee really user-friendly and high quality products.

## SIX OF 38 EXAMS TO PASS FOR RAL CERTIFICATION

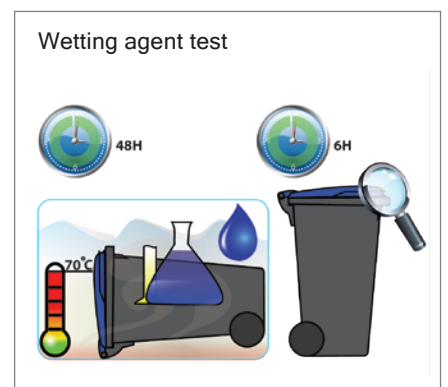
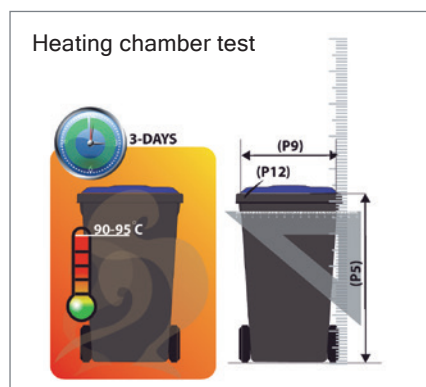
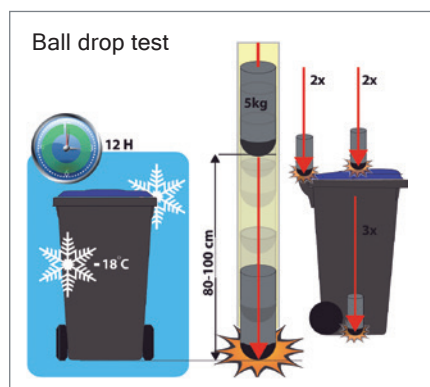
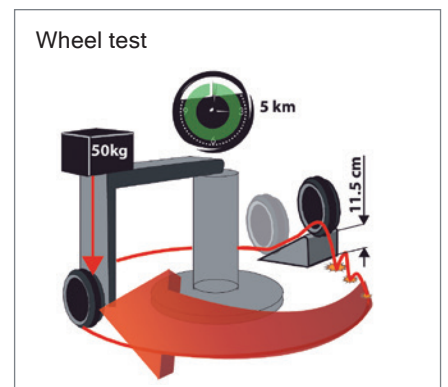



140 L CL body with SL lid



120 L SL body with CL lid



60 L body with GL lid

## WHICH OPTIONS FIT?

Body		Lid			Wheels		
		CL	SL	GL	200	250	300
Small size bin	40 L	X	X		X		
	60 L			X	X		
	80 L			X	X		
CL	120 L	X	X		X		
	140 L	X	X		X		
	180 L	X	X	X	X		
	240 L	X			X		
SL	120 L	X	X	X	X	X	
	180 L	X	X	X	X	X	
	240 L		X	X	X	X	
	360 L		X		X		X

X = only on request

The details are subject to technical changes!

## ESE - WE VALUE YOUR RECYCLABLES



KERBSIDE SYSTEMS  
MOBILE CONTAINERS FOR  
WASTE AND RECYCLABLES



BRING SYSTEMS  
(SEMI-) UNDERGROUND SYSTEMS  
COLLECTION BANKS



BIO SELECT LINE  
CONTAINERS AND COMPOSTERS  
FOR GARDEN AND BIO WASTE



HAZARDOUS WASTE CONTAINERS  
MOBILE FUEL CONTAINERS  
MOBILE OIL CHANGE UNITS



PUBLIC FURNISHING  
BINS FOR THE PUBLIC SPACE



CONTAINER MANAGEMENT  
DISTRIBUTION, REGISTRATION,  
COLLECTION AND RECYCLING

ESE is Europe's leading manufacturer of temporary storage solutions for waste and recyclables. Our comprehensive range of products is complemented by a full service offer from container management to the recycling of products at the end of their lifetime. Specialists in all departments develop solutions to meet our customers' requirements. In doing so, we follow the principle of highest possible sustainability from product development and production to transport.